



AERA ECHOCORE

Recessed

LUMENWERX

 This product must be installed in accordance with the National Electrical Code and all applicable local codes, by a person familiar with the construction and operation of the product, and the hazards involved. Proper grounding is required for safety.

Ce produit doit être installé suivant le code national de l'électricité, ainsi que tous les codes locaux applicables, par une personne familière avec la construction et le fonctionnement du produit, ainsi que tous les risques qui y sont associés. La mise à terre électrique est obligatoire pour la sécurité.

 Wire dimming conductors as Class 1.

 Shown with Aera Round EchoCore and applies to Aera Square EchoCore and Blank.

1 PREPARE CEILING OPENING.

Caution: Make sure the electrical power is turned off.

Remove ceiling tiles **[A]** where the fixture will be installed and adjacent tiles for easy access during installation.

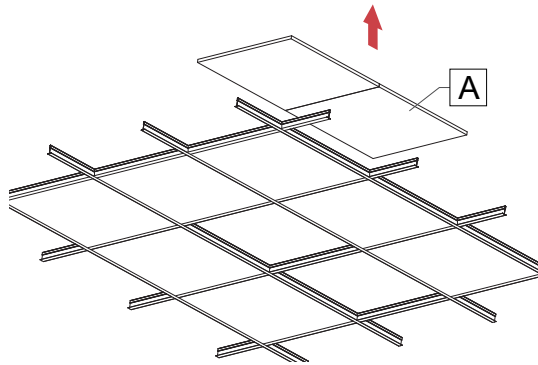

3 PLACE FIXTURE ON T-BAR GRID.

Lower the fixture **[B]** onto the T-bar grid **[C]**.

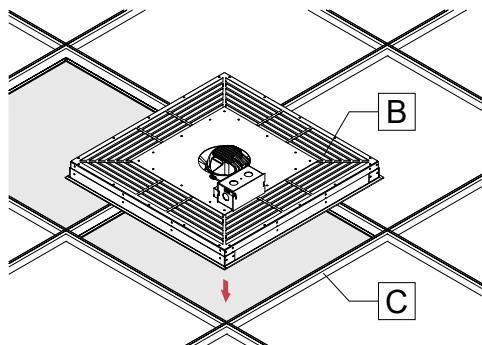

2 INSERT FIXTURE INTO THE CEILING OPENING.

Insert the fixture **[B]** above the ceiling grid.

Note: Insert carefully as to not scratch paint and to not knock out the thermal protector.

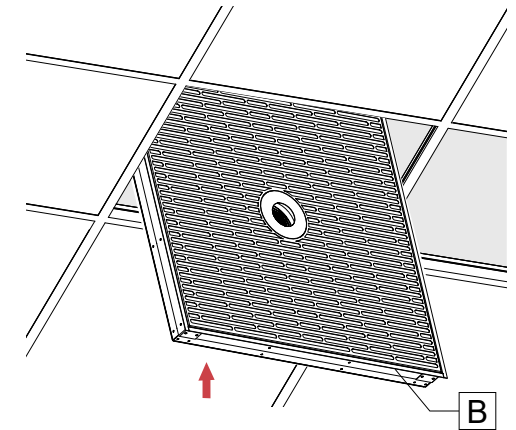

4 SECURE THE FIXTURE.

Use safety cable **[D]** to secure the fixture **[B]**.

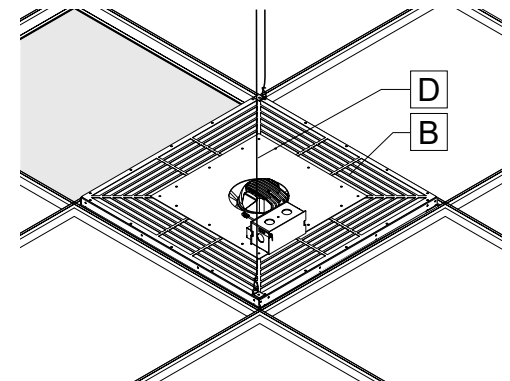
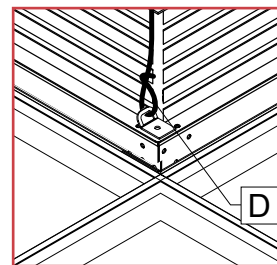

AERA ECHOCORE

Recessed

LUMENWERX

5 MAKE ELECTRICAL CONNECTIONS. (For Blank fixture skip this step)

Unsnap the cover [E] from the hook [F] and pivot the cover.

Warning: A luminaire with more than one power supply connection means shall be connected to only one branch circuit.

Install BX cable [G] to knockout and make the electrical connection with the wire nuts [H].

Snap the cover [E] back to finish.

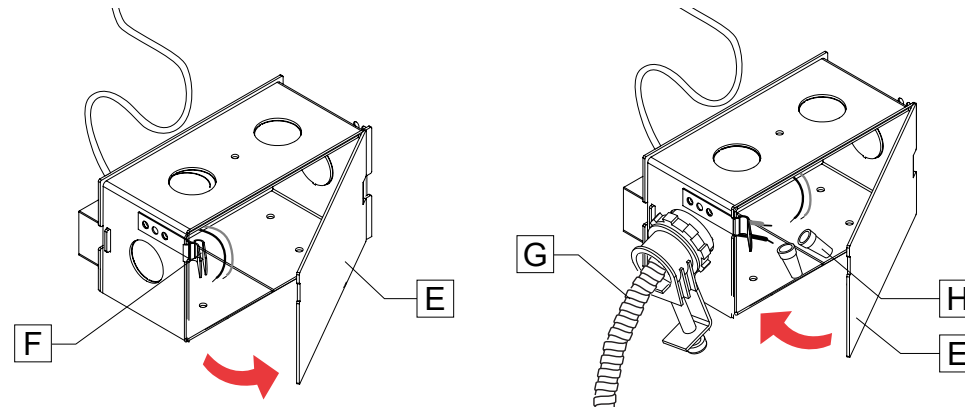

6 REINSTALL ADJACENT TILES.

Reinstall the adjacent tiles [A] on the T-bar grid [C].

