

# AERA FLEX CYLINDER

## Pendant - Direct mount



This product must be installed in accordance with the National Electrical Code and all applicable local codes, by a person familiar with the construction and operation of the product, and the hazards involved. Proper grounding is required for safety.

Ce produit doit être installé suivant le code national de l'électricité, ainsi que tous les codes locaux applicables, par une personne familière avec la construction et le fonctionnement du produit, ainsi que tous les risques qui y sont associés. La mise à terre électrique est obligatoire pour la sécurité.



Wire dimming conductors as Class 1.



For electrical connections, please refer to the [wiring diagram guide](#).



### OVERVIEW

#### Junction box (by others) - for new construction

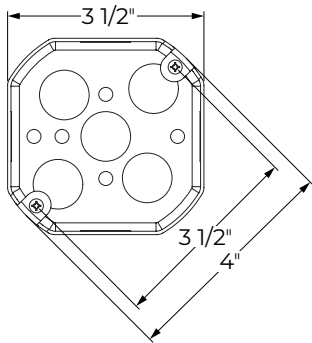
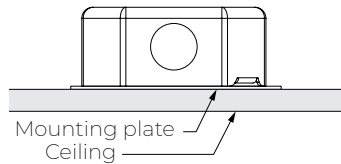
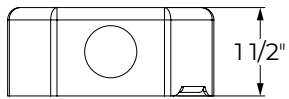

Standard 4" octagonal junction box

#### Stem

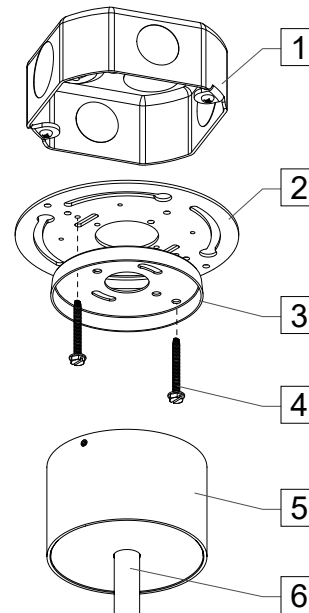

#### Index

Go to pages related to product configuration.

New construction.....P.2  
Remodel.....P.4

#### Tools Required

- Allen key 5/64
- Philips screwdriver
- Gypsum cutter or milling hand tool

#### Items list

1	Standard J-box (by others)
2	Mounting plate
3	Adapter piece
4	6-32 screw
5	Housing assembly
6	Stem



For remote driver box, please refer to the [remote driver installation sheet](#) for more information.



# AERA FLEX CYLINDER

Pendant - Direct mount



## JUNCTION BOX (Install option A - New construction)

### 1 INSTALL JUNCTION BOX AND MOUNTING PLATE.

Install and reinforce junction box [A] (by others) to ceiling structure.

Mount and turn the mounting plate [B] to place on the junction box. Tighten screws to secure the mounting plate to the junction box.

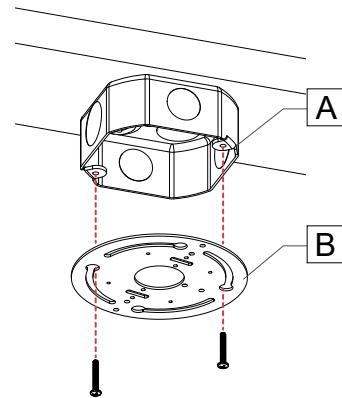

### 3 INSTALL ADAPTER PIECE TO CEILING.

Unlock set screws [D] from the housing assembly, using the provided allen key.

Pass the remote driver feed through the adapter piece [E].

Attach the adapter piece [E] to the mounting plate [B] with 2x 6-32 screws [F] provided.

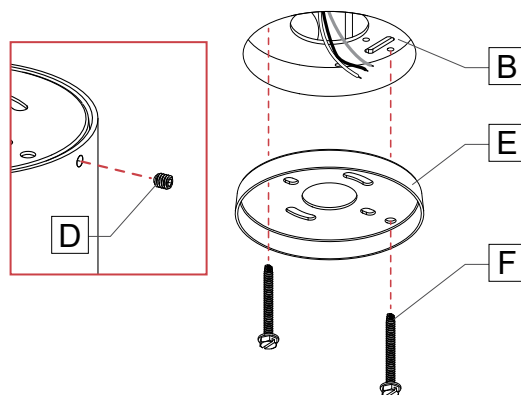

### 2 PREPARE DRYWALL CEILING.

Install the drywall [C]. Prepare the area where the fixture is going to be installed. Cut hole in the drywall.

Cut a 2 3/4" dia hole in the drywall.

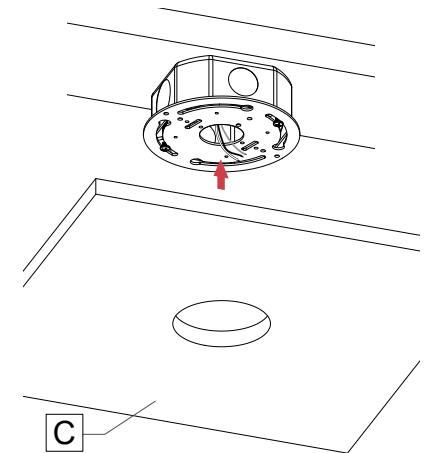

### 4 MAKE ELECTRICAL CONNECTIONS.

Make electrical connections between the fixture cable [G] and the remote driver feed [H] using wire nuts (by others).

**Note:** Number of wires may vary.

**Warning:** A luminaire with more than one power supply connection means shall be connected to only one branch circuit.

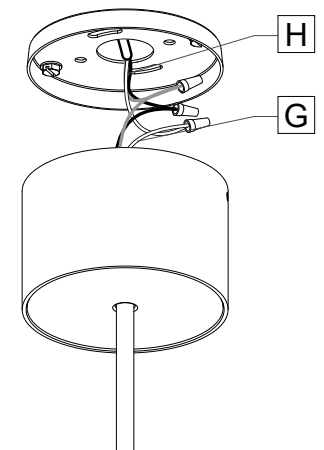

# AERA FLEX CYLINDER

Pendant - Direct mount



## 5 INSTALL HOUSING ASSEMBLY.

Put the housing assembly [I] back to the adapter piece [E] and lock 2x 8-32 set screws [D].

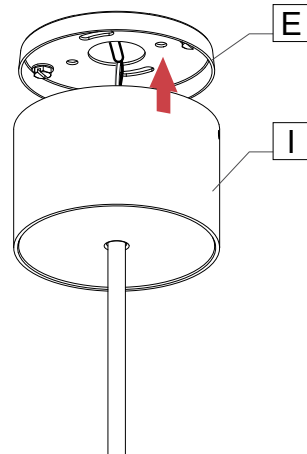
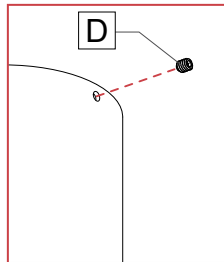

# AERA FLEX CYLINDER

## Pendant - Direct mount



### DIRECT FEED (Install option B - Remodel)

#### 1 INSTALL ADAPTER PIECE TO CEILING.

Remove set screws [A] from the housing assembly [B].

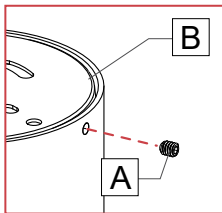

Locate where the fixture will be installed. Use the adapter piece [C] as a model to mark 2 mounting points and a 7/8" dia hole.

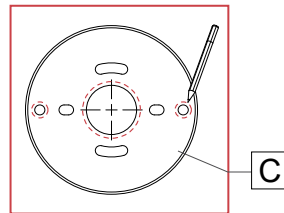

Pierce a 7/8" dia hole and bring the remote driver feed [D] through the hole and connect the remote driver feed to the adapter [E] (by others).

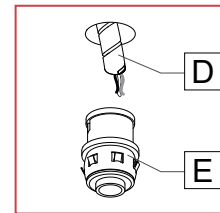

Install screw anchors [F] (by others) where the hole was made and install the adapter piece [C] with screws (by others).

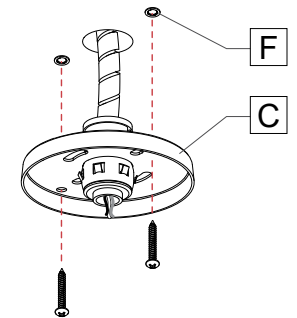

#### 2 MAKE ELECTRICAL CONNECTIONS.

Make electrical connections between the fixture cable [G] and the remote driver feed [D] using wire nuts (by others).

**Note:** Number of wires may vary.

**Warning:** A luminaire with more than one power supply connection means shall be connected to only one branch circuit.

**Note:** No daisy chain connections allowed.

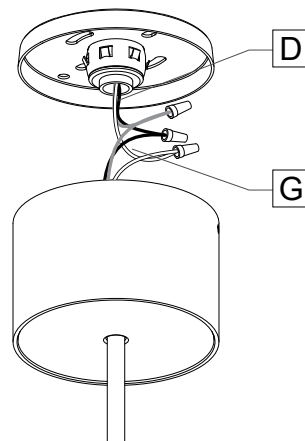

#### 3 INSTALL HOUSING ASSEMBLY.

Place the housing assembly [B] back to the adapter piece [C] and secure with the provided set screws [A].

