

! This product must be installed in accordance with the National Electrical Code and all applicable local codes, by a person familiar with the construction and operation of the product, and the hazards involved. Proper grounding is required for safety.

Ce produit doit être installé suivant le code national de l'électricité, ainsi que tous les codes locaux applicables, par une personne familière avec la construction et le fonctionnement du produit, ainsi que tous les risques qui y sont associés. La mise à terre électrique est obligatoire pour la sécurité.

! Wire dimming conductors as Class 1.

! Fixtures with an output of 1000 lm/ft or higher must not be installed in IC conditions.

! Fixtures shown with 2".

REMOTE DRIVER

1 INSTALL REMOTE DRIVER.

Caution: Make sure the electrical power is turned off.

Please refer to the remote driver installation sheet for more informations.

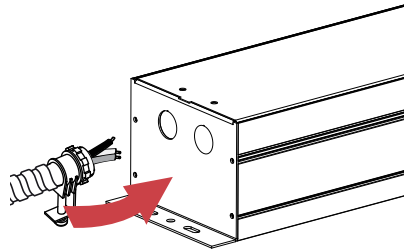

2 INSTALL CANOPY PLATE.

Detach the canopy [A] from the canopy plate [B].

Install the canopy plate [B] on the junction box [C] with screws [D].

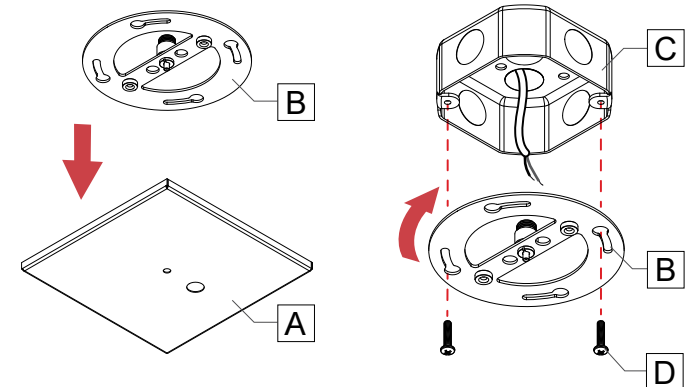

3 INSTALL AIRCRAFT CABLES.

Pass the aircraft cable [E] through the canopy [A]. Cut the excess cable with an aircraft cable cutter [F]. Insert them into the gripper then adjust the cables [E] by pushing the feeder tube.

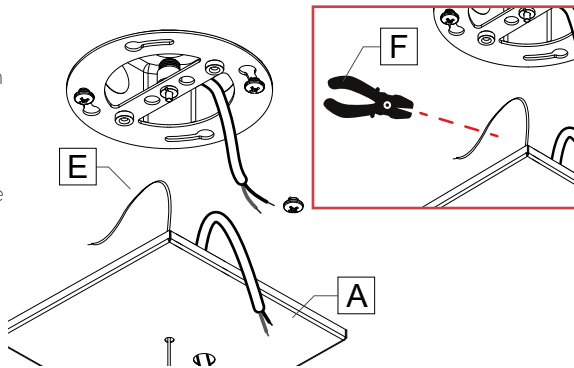

4 MAKE ELECTRICAL CONNECTION.

Make the electrical connection between the power cord [G] and the main power [H] with the marettes [I].

Push all connected wires inside the junction box. Put the canopy [A] back in place.

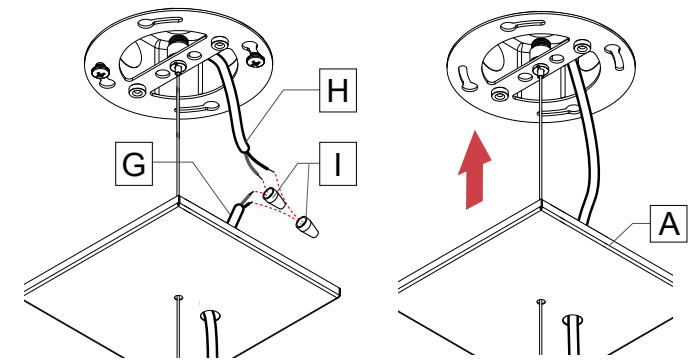

5 SECURE POWER CORD.

Secure power cord [G] to aircraft cable [E] with plastic clip [J].

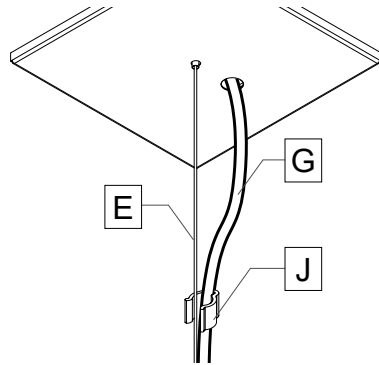

CONTINUOUS RUN

1 FOR CONTINUOUS RUN, REPEAT STEPS **1** TO **5** FROM THE SINGLE FIXTURE SECTION FOR ALL OF THE FIXTURES IN THE RUN.

2 REMOVE LENSES.

Remove the lenses [K] from all the fixtures in the run with the provided lens tool [L].

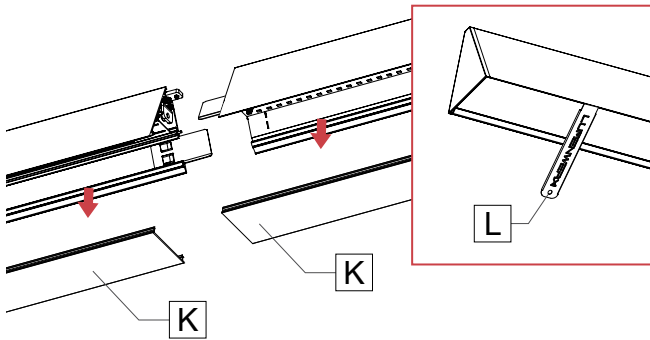

3 DISCONNECT LED AND REMOVE CARTRIDGE(S).

Disconnect LED moxex connector [M] by taking a pointed object and pressing on the two tabs on top.

Remove the cartridges [N] from the joining ends of the fixtures in the run.

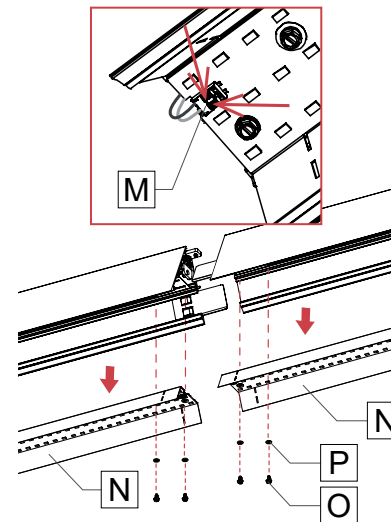

Note: Reflector must be reinstalled with the screw and plastic washer that was originally supplied. If not, it can result in an electrical failure.

Make sure to keep the screw [O] and washer [P] to later reconnect the wires to the LED boards correctly.

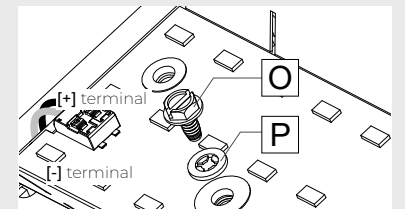

4 MAKE ELECTRICAL CONNECTIONS.

Connect wires between joining fixture using quick connectors [Q]. Number of wires may vary.

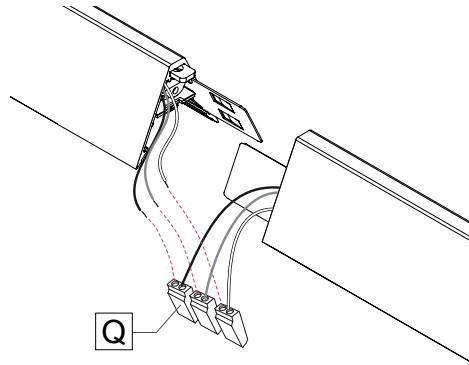

5 JOIN FIXTURES.

Join the fixtures [R] and put back the joiner screw [S] in place. Tighten the screw (using the provide 3/16" Ball-End screwdriver) to pull the extrusions [R] together.

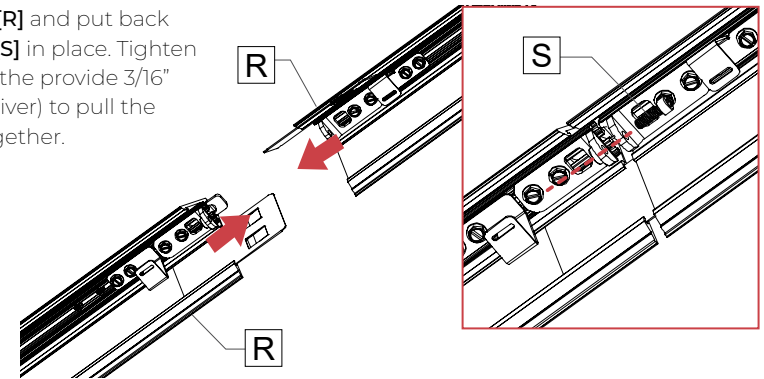

6 RECONNECT AND REINSTALL CARTRIDGES.

Reinstall all cartridges [N] and reconnect the LED mollex connector [M].

Make sure that the wires are not hiding any LED diode. Screw the cartridges back in place by using screw with plastic washer.

Warning: Do not apply too much pressure.

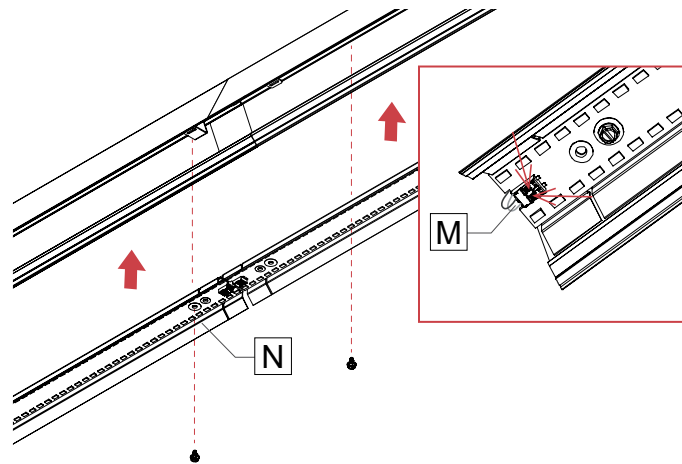

7 REINSTALL LENSES.

Reinstall lenses [K] for all fixtures in the run.

