

! This product must be installed in accordance with the National Electrical Code and all applicable local codes, by a person familiar with the construction and operation of the product, and the hazards involved. Proper grounding is required for safety.

Ce produit doit être installé suivant le code national de l'électricité, ainsi que tous les codes locaux applicables, par une personne familière avec la construction et le fonctionnement du produit, ainsi que tous les risques qui y sont associés. La mise à terre électrique est obligatoire pour la sécurité.

! Wire dimming conductors as Class 1.

💡 For electrical connections, follow the wiring diagrams on page 5 according to specified drivers in product configuration.

💡 Shown with Curvia 2 and applies to 3 and 4 too.

💡 For remote driver box, please refer to the [remote driver installation sheet](#) for more information.

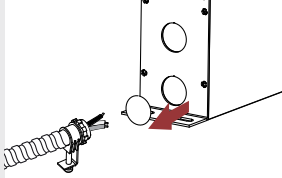

Option 1 - INSTALLATION BEFORE DRYWALL CEILING HAS BEEN INSTALLED SINGLE FIXTURE

1 PREPARE THE CEILING.

Prepare the area where the fixture is going to be installed. Locate the threaded rods **[A]** according to the dimensions **[*]** given in the client drawings.

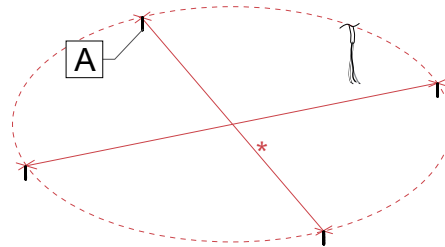

Number of threaded rods may vary.

3 CONNECT THE FIXTURE TO THE MAIN POWER.

Install power cable **[D]** (by others) through the BX connector **[E]** (by others) and install onto the power plate **[F]** provided. Make electrical connections between power cable **[D]** and fixture cables **[C]** using wire nuts **[H]**. Reinstall the power plate **[F]** to the fixture **[B]**.

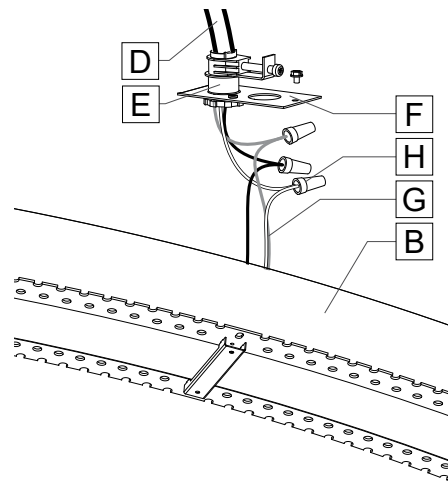

Number of wires may vary.

2 PREPARE THE FIXTURE.

Make sure the power to the fixture **[B]** is turned off, the lens is installed on the fixture and protected by a cover. Make sure the spacer brackets **[C]** are in place, aligned with the obround holes of the flanges.

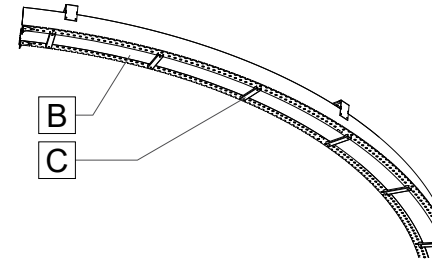

4 INSTALL THE FIXTURE TO THE CEILING.

Align the threaded rods **[A]** with holes on top of fixture mounting bracket **[I]**. Use washers **[J]** and tighten nuts **[K]** to secure the fixture **[B]**.

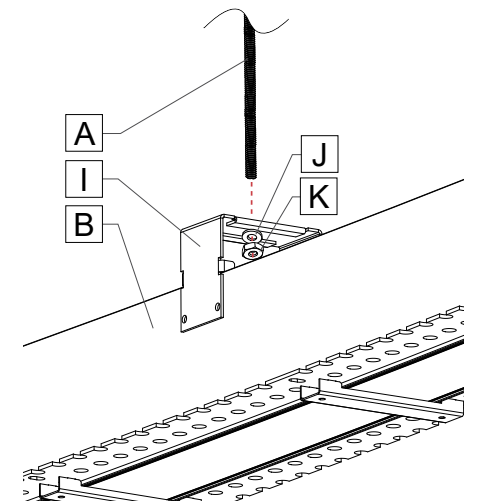

Index

Go to pages related to product configuration.

Option 1 - Installation BEFORE ceiling	
Single fixture	P.1
Continuous run.....	P.2
Option 2 - Installation AFTER ceiling	
Single fixture	P.3
Continuous run.....	P.4

CURVIA

Recessed - Drywall mud flange

5 FIX THE FIXTURE ON THE DRYWALL.

After installing the drywall ceiling, secure the fixture [B] to the ceiling by fastening drywall screws [L] through the obround holes of the mud flanges [M] into the ceiling. Framing [N] around the fixture is necessary for a good installation.

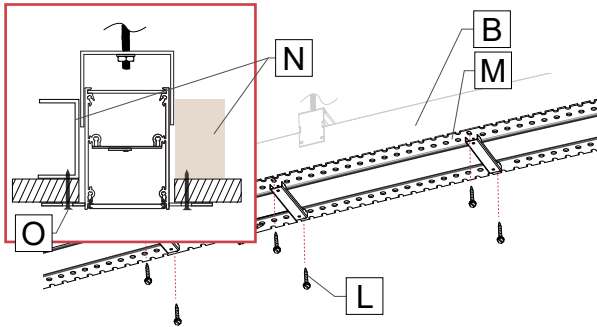

6 REMOVE THE BRACKETS.

Once the fixture is attached to the drywall, remove the spacer brackets [C].

Note: For continuous run, also remove the joiners [O].

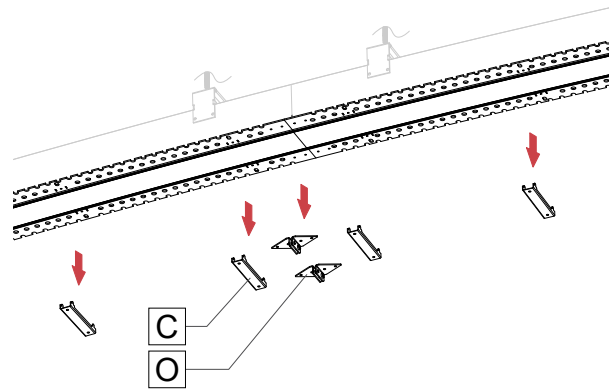

7 PLASTER THE MUD FLANGES.

Plaster and sand over mud flanges [M] to create a smooth finish.

Once the mud is totally dry and painted, gently remove the cover [P].

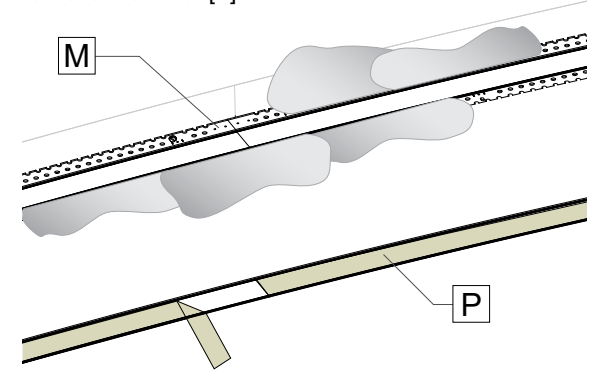

CONTINUOUS RUN

1 FOR CONTINUOUS RUN, REPEAT STEPS 1 - 4 FROM THE SINGLE FIXTURE SECTION FOR THE FIRST FIXTURE IN THE RUN.

2 ELECTRICAL CONNECTIONS.

Raise the second fixture [Q]. Make the wire connection between the two sections using wire connectors [R]. Number of wires may vary.

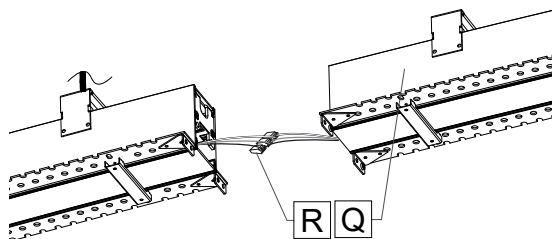

3 SECURE THE SECOND FIXTURE TO THE CEILING.

Align the threaded rods [A] with holes on top of the second fixture mounting brackets [I]. Use washers [J] and tighten nuts [K] to secure the fixture [Q].

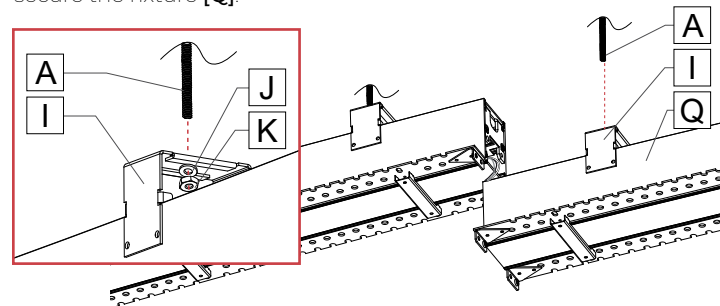

4 JOIN THE FIXTURES.

Join the fixture [B] to the fixture [Q]. Attach the two fixtures by fastening screws on the joiners [O].

Repeat steps 2-4 for all sections in the run.

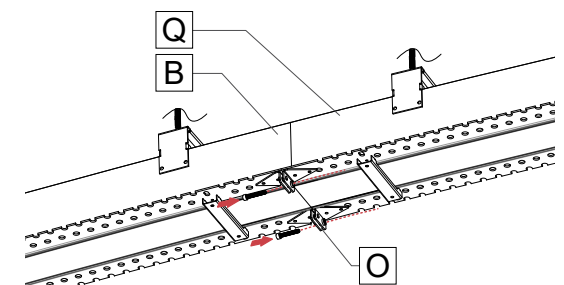

5 REPEAT STEPS 5 - 7 FROM THE SINGLE FIXTURE SECTION FOR THE ALL THE FIXTURES IN THE RUN.

CURVIA

Recessed - Drywall mud flange

LUMENWERX

Option 2 - INSTALLATION AFTER DRYWALL CEILING HAS BEEN INSTALLED SINGLE FIXTURE

1 PREPARE THE CEILING.

Prepare the area where the fixture is going to be installed. Cut hole in the drywall according to the dimensions [M] given in the client drawings.

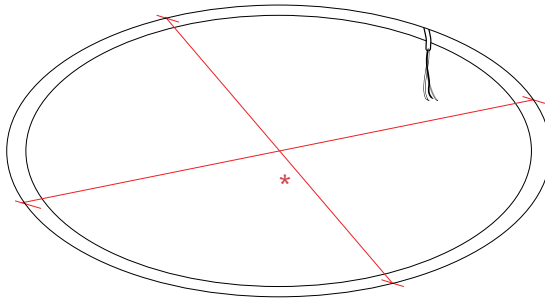

2 PREPARE THE FIXTURE.

Make sure the power to the fixture [B] is turned off, the lens is installed on the fixture and protected by a cover. Make sure the spacer brackets [C] are in place, aligned with the obround holes of the flanges.

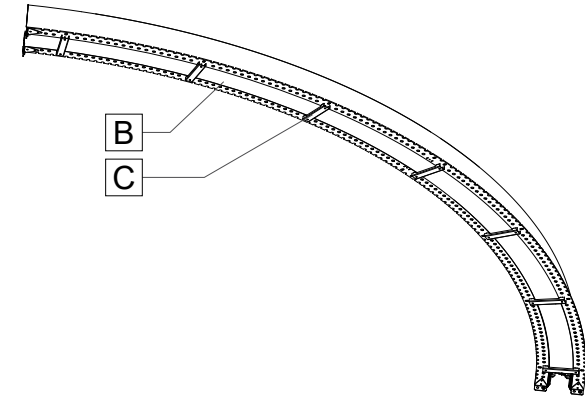

3 CONNECT THE FIXTURE TO THE MAIN POWER.

Install power cable [D] (by others) through the BX connector [E] (by others) and install onto the power plate [F] provided. Make electrical connections between power cable [D] and fixture cables [G] using wire nuts [H]. Reinstall the power plate [F] to the fixture [B].

Number of wires may vary.

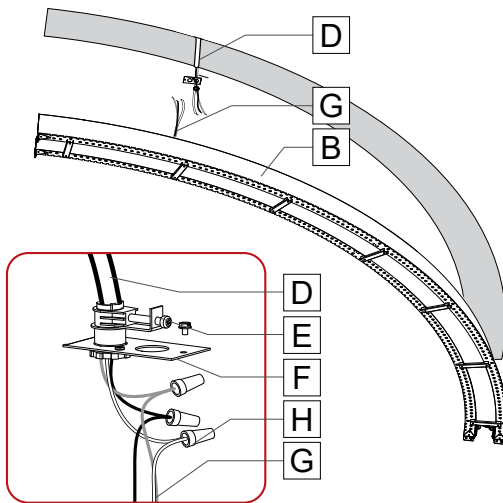

4 INSTALL THE FIXTURE TO THE CEILING.

Fasten drywall screws [L] through the obround holes of the mud flanges [M].

Framing [N] around the fixture is necessary for a good installation.

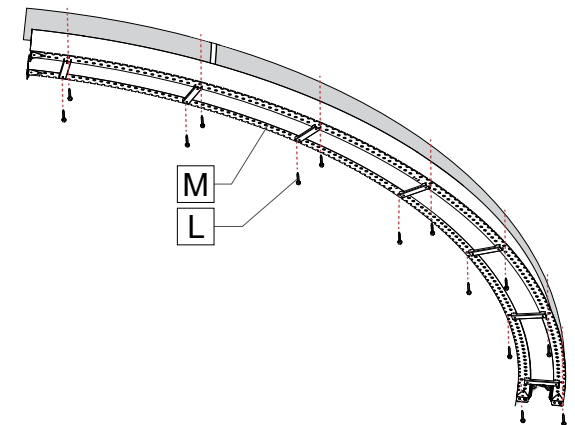
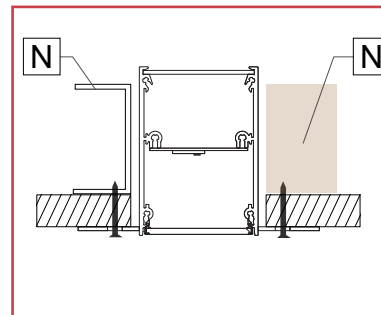

CURVIA

Recessed - Drywall mud flange

5 REMOVE THE BRACKETS.

Once the fixture is attached to the drywall, remove the spacer brackets [C].

Note: For continuous run, also remove the joiners [O].

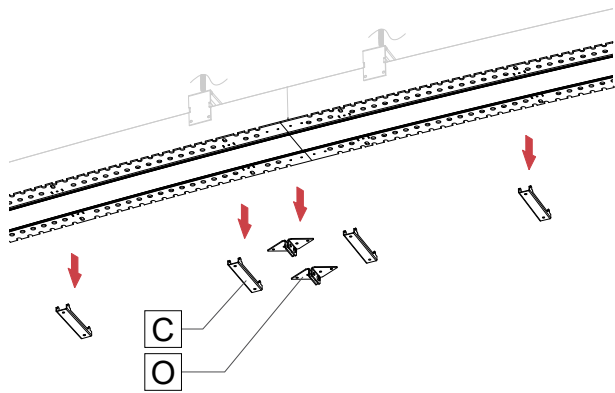

6 PLASTER THE MUD FLANGES.

Plaster and sand over mud flanges [M] to create a smooth finish.

Once the mud is totally dry and painted, gently remove the cover [P].

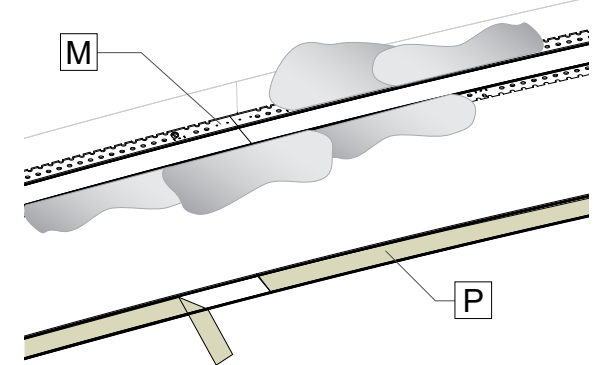

CONTINUOUS RUN

1 FOR CONTINUOUS RUN, REPEAT STEPS 1 - 4 FROM THE SINGLE FIXTURE SECTION FOR THE FIRST FIXTURE IN THE RUN.

2 ELECTRICAL CONNECTIONS.

Make the wire connection between the first two sections using wire connectors [R]. Insert the second section [Q] into the drywall hole.

Number of wires may vary.

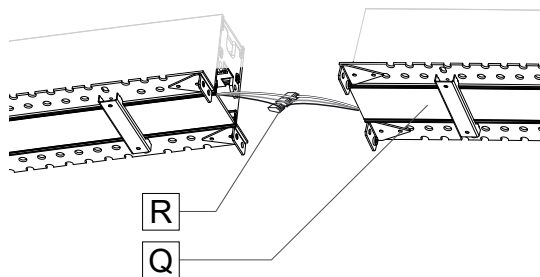

3 JOIN THE FIXTURES.

Join the fixture [B] to the fixture [Q]. Attach the two fixtures by fastening screws on the joiners [O].

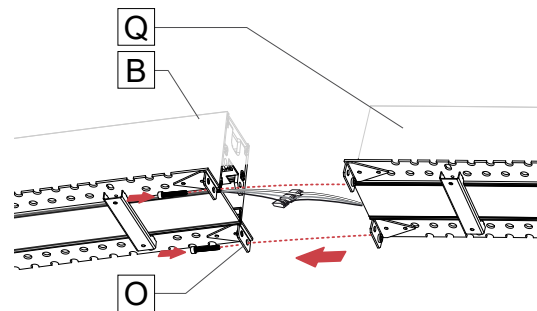

4 INSTALL THE FIXTURE TO THE CEILING.

Fasten drywall screws [L] through the obround holes of the mud flanges [M].

Framing [N] around the fixture is necessary for a good installation.

Repeat steps 2-4 for all sections in the run.

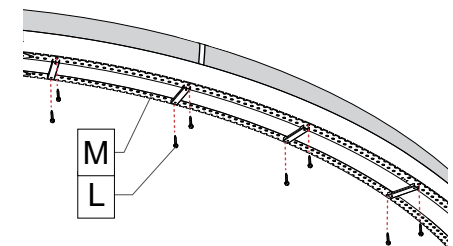
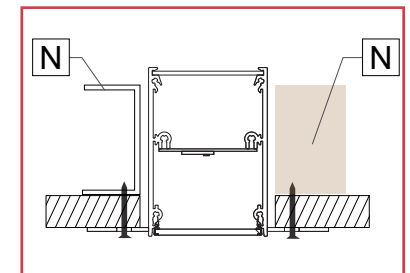

5 REPEAT STEPS 5 - 6 FROM THE SINGLE FIXTURE SECTION FOR THE ALL THE FIXTURES IN THE RUN.

CURVIA

Recessed - Drywall mud flange

WIRING DIAGRAMS (1 Circuit)

For electrical connections, follow the wiring diagrams according to specified drivers in product configuration.

REMOTE DRIVER - STATIC WHITE

RED	LED (+)
BLUE	LED (-)

Note:
For remote driver wiring in the remote driver box (RDB), refer to the applicable integral driver wiring.

For max wire distance from driver, please check our website: WWW.LUMENWERX.COM

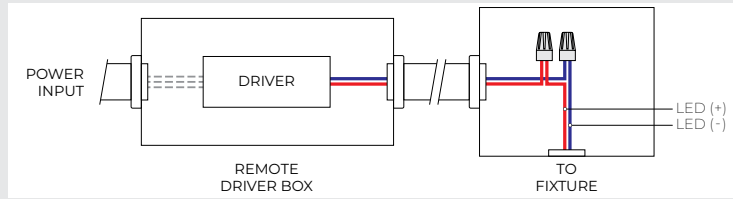

INTEGRAL DRIVER - STATIC WHITE

D1 / ELD1 / ELDO

BLACK	HOT
WHITE	NEUTRAL
GREEN	GROUND
PURPLE	DIM (+) 0-10V
PINK or GRAY	DIM (-) 0-10V

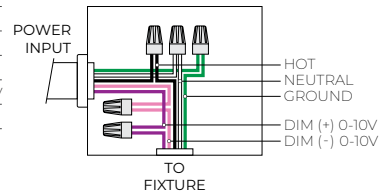

DA

BLACK	HOT
WHITE	NEUTRAL
GREEN	GROUND
PURPLE	DALI (+)
PINK or GRAY	DALI (-)

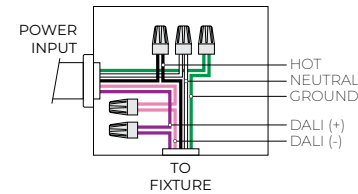

LTEA2W

BLACK	HOT
WHITE	NEUTRAL
GREEN	GROUND

Note:
120V max input voltage

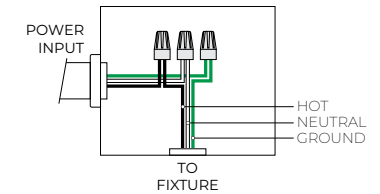

LDE1

BLACK	HOT
WHITE	NEUTRAL
GREEN	GROUND
PURPLE	E1 TO ECOSYSTEM
PINK or GRAY	E2 DIGITAL LINK

