

SHELL ROUND

PENDANT STEM - REMOTE DRIVER - INST

IMPORTANT : Installation INST. are shown with SHELL 12" (Do not handle fixture by the wires)

NOTE: Wire dimming conductors as Class 1

1 REMOTE DRIVER BOX

Please refer to the remote driver installation sheet for more informations.

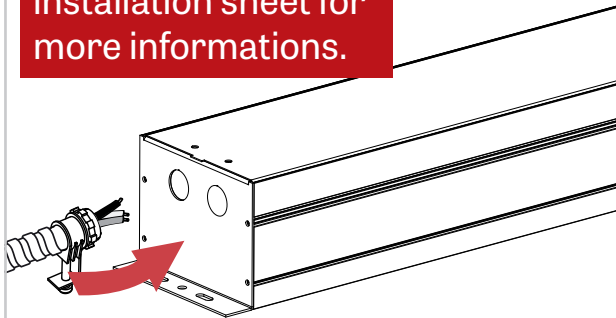

2

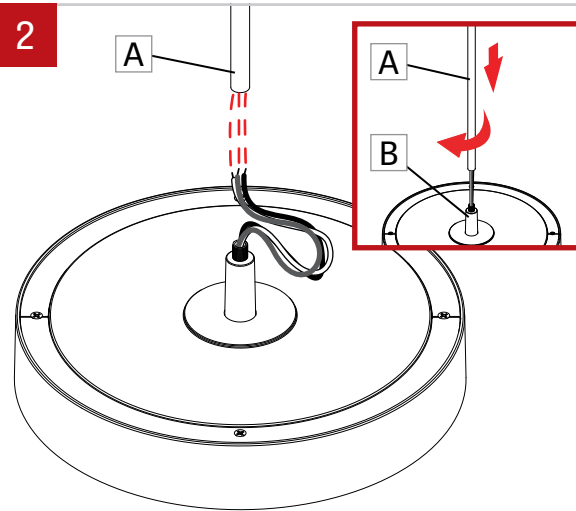

Pass the wires through the stem(A). Assemble the stem (A) into the cone (B) by screwing it.

3

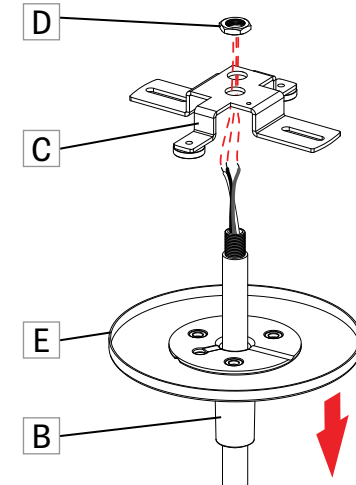

Pass the wires through the middle hole of the cross-bracket (C) and nut (D). Lower the canopy (E) and the cone (B) along the stem(C).

4

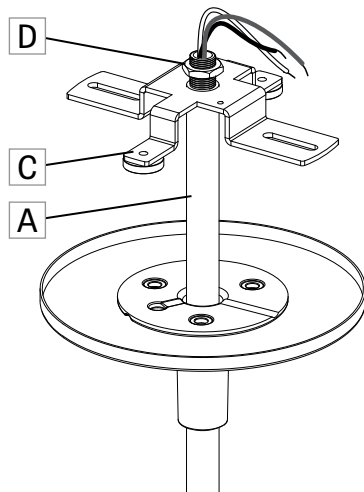

Install the cross-bracket (C) on the stem (A) by using the nut (D).

5

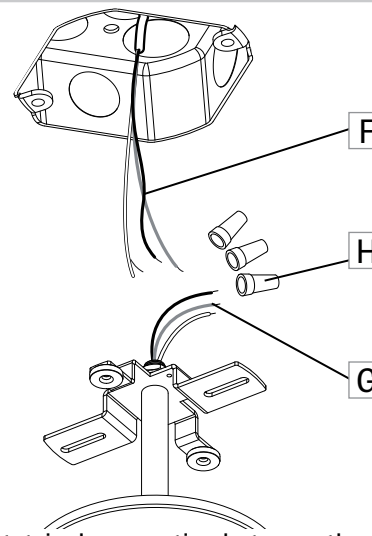

Make the electrical connection between the wires (F) from the building and the wires (G) from the PCB with the marettes (H).

6

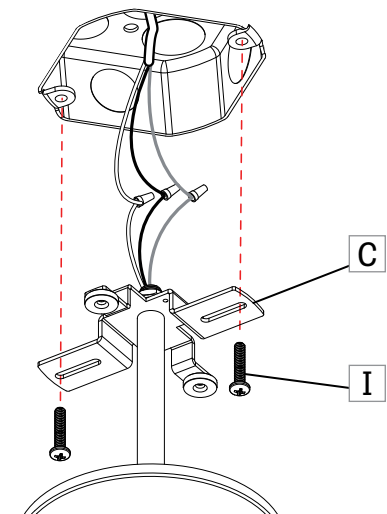

Install the cross-bracket (C) on the junction box with screws (I).

7

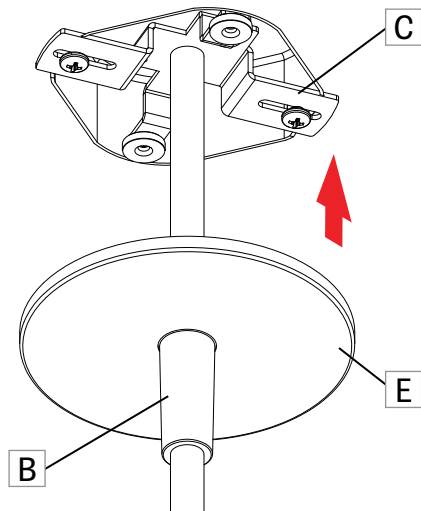

Attach the canopy (E) and the cone (B) on the magnetic cross-bracket (C).