

SHELL 24 ROUND

PENDANT CABLE - INTEGRATED DRIVER - INST

IMPORTANT : Do not handle fixture by the wires

NOTE: Wire dimming conductors as Class 1

1

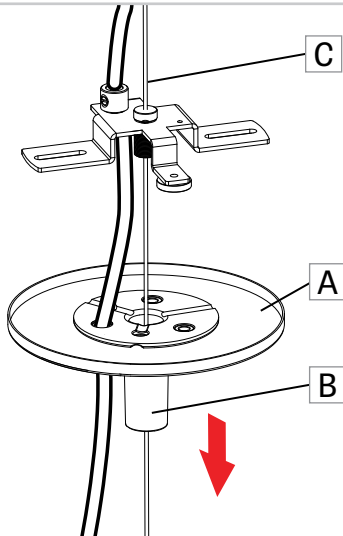

Lower the canopy(A) and the cone(B) along the aircraft cable(C).

2

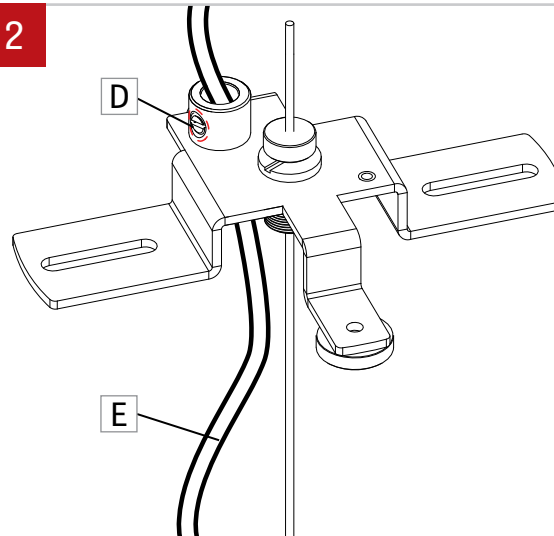

Tighten the screw(D) to secure the power cord(E) with the strain relief(F).

3

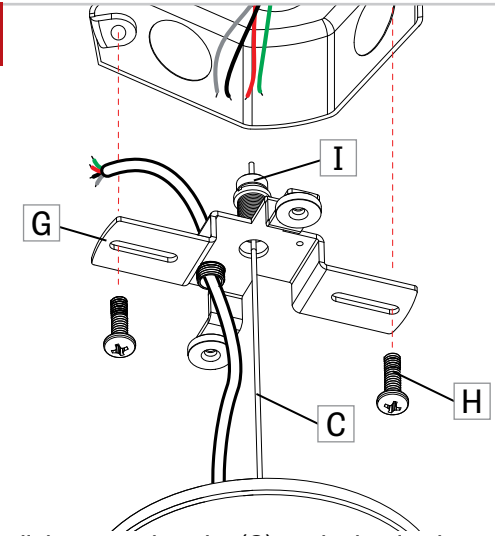

Install the cross-bracket(G) on the junction box with screws(H). Adjust the aircraft cable(C) length by pushing the feeder tube(I).

4

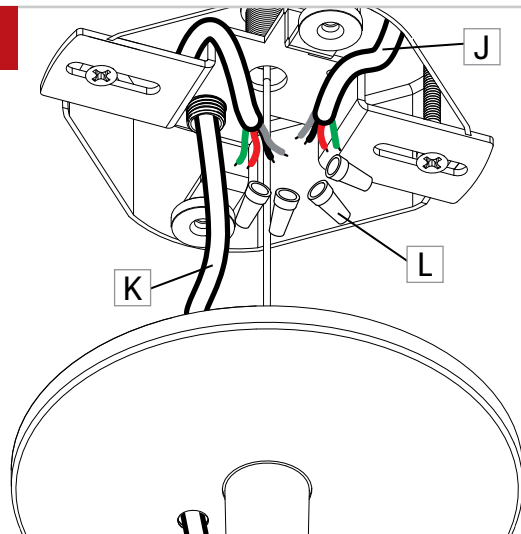

Make the electrical connection between the wires(J) from the building and the power cord(K) on the fixture with the marettes(L).

5

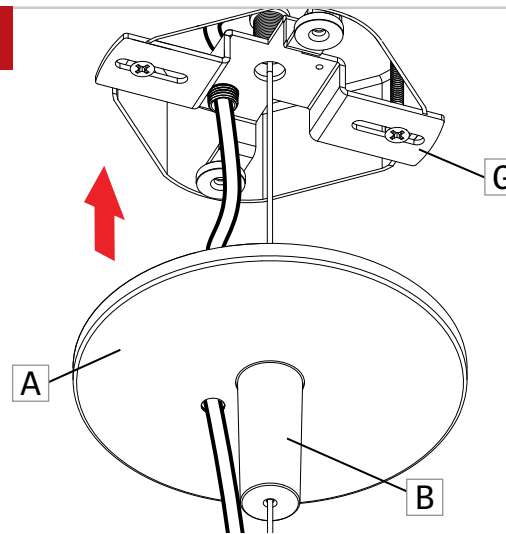

Attach the canopy(A) and the cone(B) on the magnetic cross bracket(G).

6

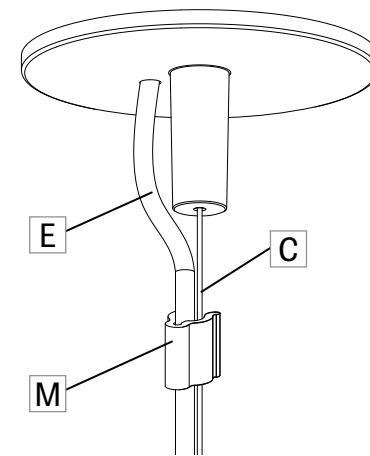

Secure the power cord(E) to the aircraft cable(C) with the plastic clip(M).