

# SHELL 24 ROUND

PENDANT STEM - INTEGRATED DRIVER - INST

**IMPORTANT:** Do not handle fixture by the wires

**NOTE:** Wire dimming conductors as Class 1

1

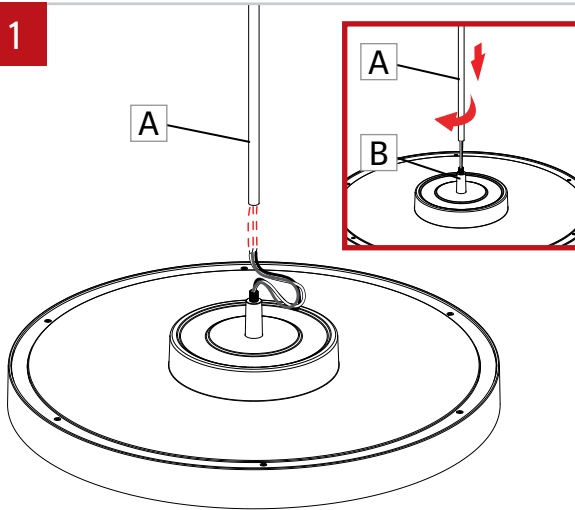

Pass the wires through the stem (A). Assemble the stem (A) into the cone (B) by screwing it.

2

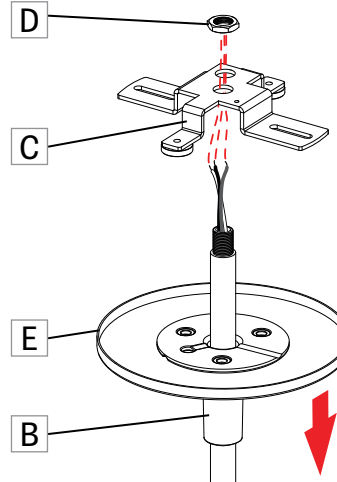

Pass the wires through the middle hole of the cross-bracket (C) and nut (D). Lower the canopy (E) and the cone (B) along the stem (C).

3

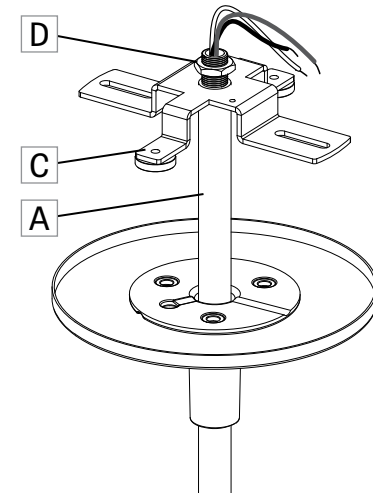

Install the cross-bracket (C) on the stem (A) by using the nut (D).

4

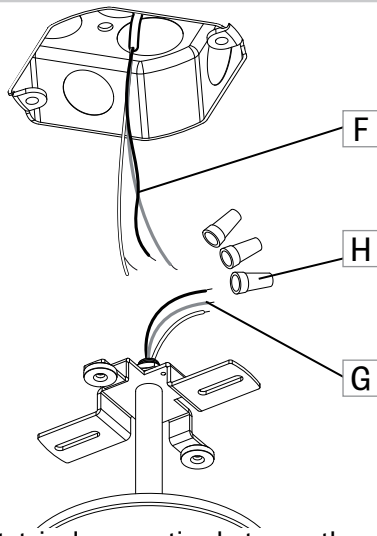

Make the electrical connection between the wires (F) from the building and the power cord (G) from the driver with the marettes (H).

5

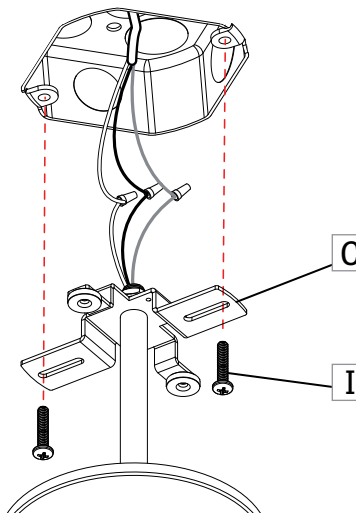

Install the cross-bracket (C) on the junction box with screws (I).

6

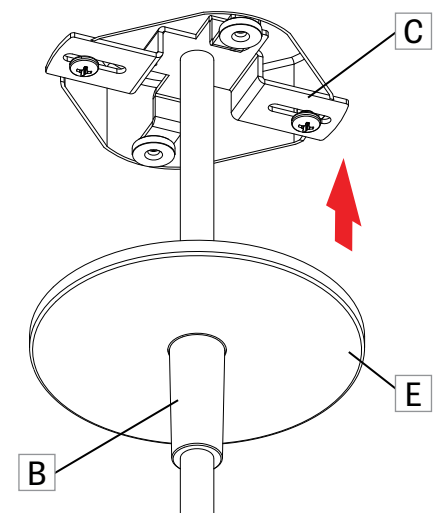

Attach the canopy (E) and the cone (B) on the magnetic cross-bracket (C).