

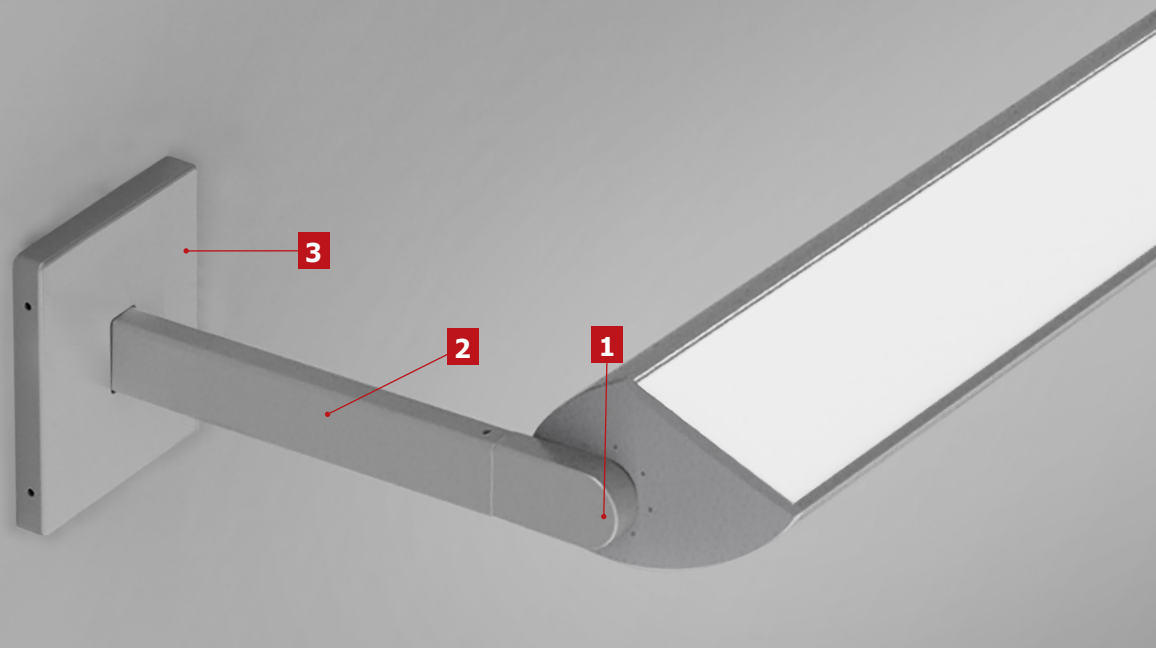

AXLE

Elegant linear accent lighting that is both flexible and efficient

Axle is an elegant and compact LED linear accent luminaire providing efficient asymmetric light distribution. Softly curved, Axle measures just 2 1/16" by 3 1/16". With adjustable optics, light output from 350 to 1200 lumens per foot (nominal) and efficacy up to 126 LPW, Axle delivers very effective illumination to graphics and artwork, as well as ceilings and walls. Highly flexible, Axle can be installed as individual luminaires (up to 8') or in continuous runs, with a choice of arm or cable suspension. LED boards and driver are accessible without removing the luminaire.



(1) ROTATION HUB

Mounting hub provides field adjustment for precise aiming.

(2) CANTILEVER ARM

Die-formed steel provides cantilevered extension of 6", 12" or 18" and conceals wiring.

(3) MOUNTING PLATES

Arm mounting provides concealed wiring and connects to outlet boxes using 4" square and round mounting plates.

(4) WHITE BAFFLE

Optional die-formed sheet metal white baffle with blades, spaced 1/2" apart, provides lateral shielding and can be field installed. The baffles are in sheet metal.

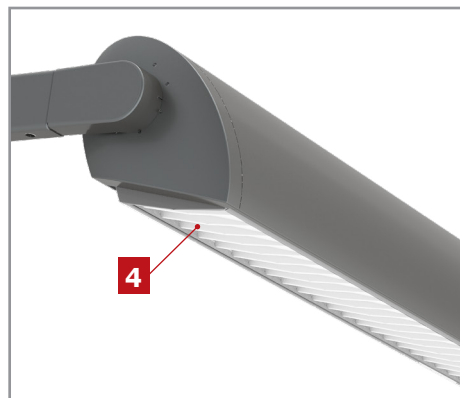

PENDANT

Axle cable direct

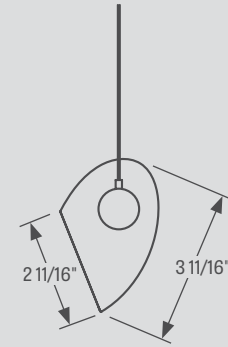

Axle arm direct

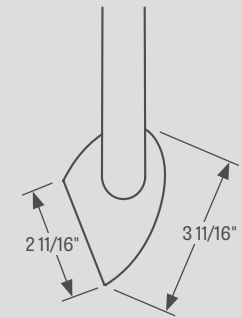

WALL

Axle arm direct

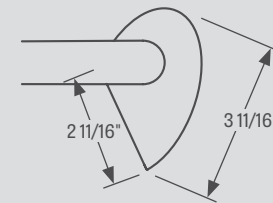

Axle arm indirect

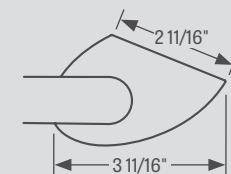

AXLE

Asymmetric Projecting Optic

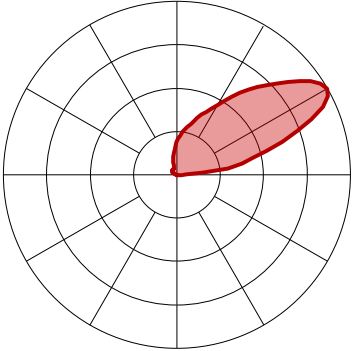

Cartridge-mounted, linear LED arrays are paired with a precisely formed semi-specular reflector for smooth light distribution and a 95° beam spread. The LED array is protected by a clear acrylic cover. In an indirect orientation, peak intensity occurs at 120° above nadir with a peak-to-zenith intensity ratio of 5.2:1. The Axle housing can be field rotated in 15° increments which permit precise aiming.

Field Adjustable Aiming

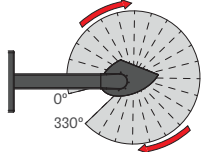
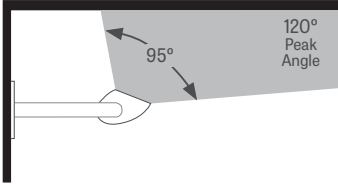

Wall asymmetric indirect

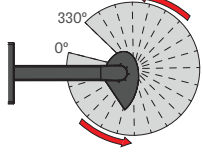
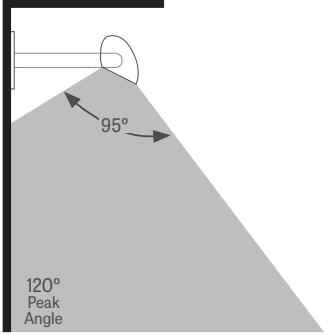

Wall asymmetric direct



Axle pendant asymmetric